

PLANO DE CONTROL PARA HIDRONEUMATICO (2 BOMBAS Y UN COMPRESOR)

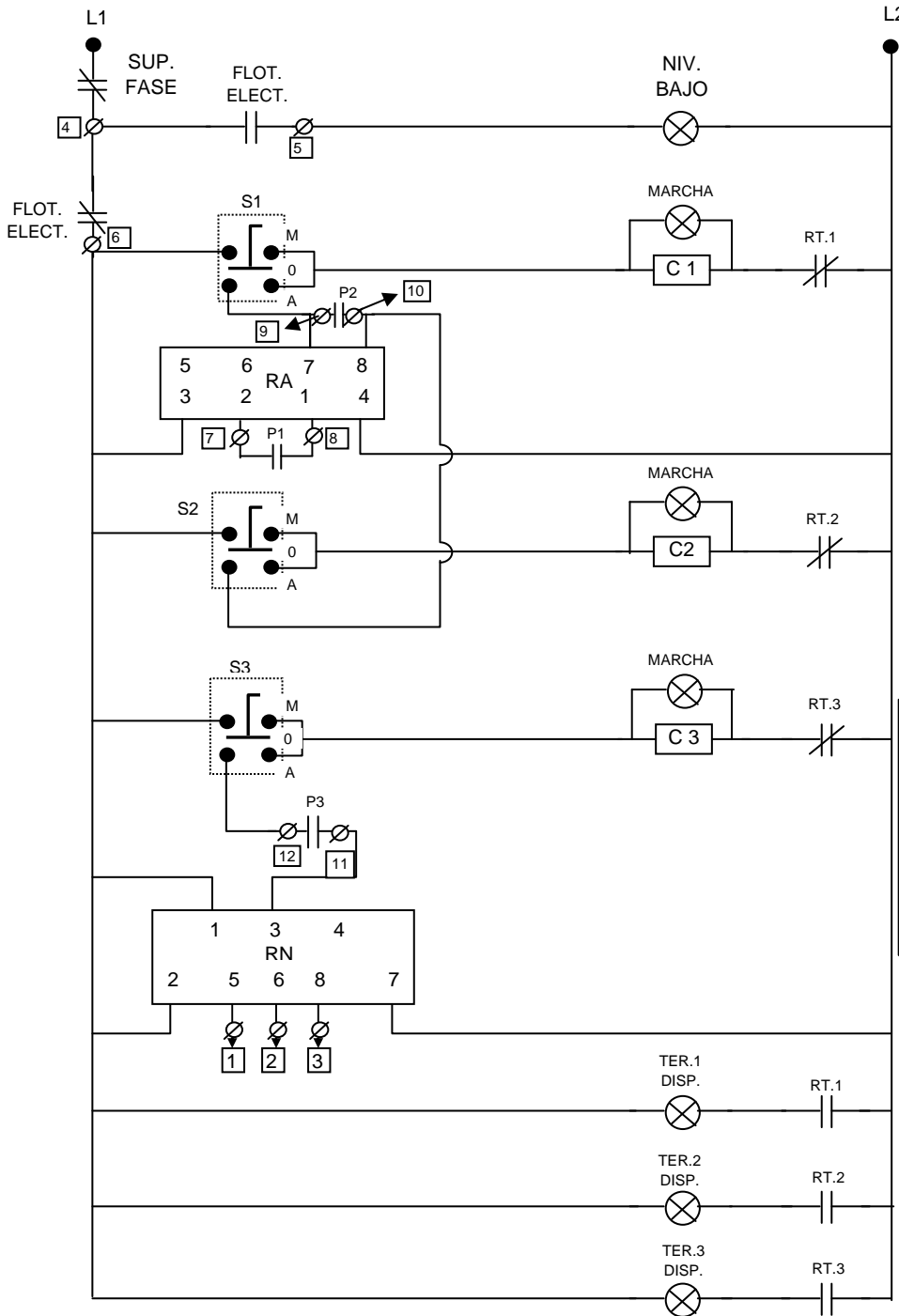

- C1 = CONTACTOR BOMBA 1
- C2 = CONTACTOR BOMBA 2
- C3 = CONTACTOR COMPRESOR
- RT1 = RELE TERMICO BOMBA 1
- RT2 = RELE TERMICO BOMBA 2
- RT3 = RELE TERMICO COMPRESOR
- RA = RELE ALTERNADOR
- RN = RELE CONTROL DE NIVEL
- S1 = SELECTOR MAN - AUTO BOMBA 1
- S2 = SELECTOR MAN - AUTO BOMBA 2
- S3 = SELECTOR MAN - AUTO COMPRESOR
- P1 = PRESOSTATO DE ALTERNANCIA
- P2 = PRESOSTATO DE EMERGENCIA
- P3 = PRESOSTATO DE COMPRESOR

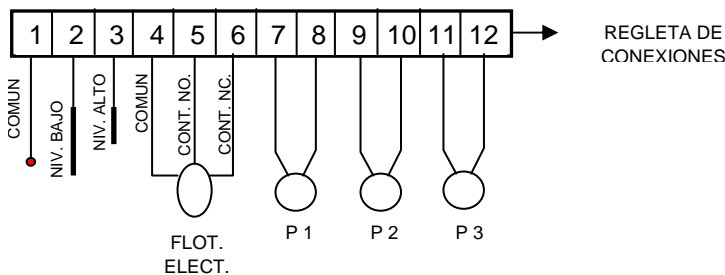
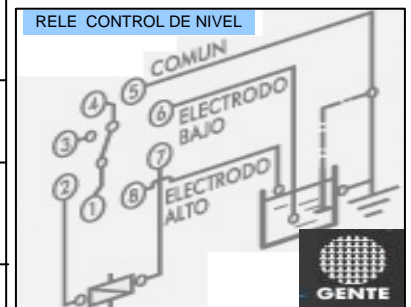

PLANO DE POTENCIA

